

CGの使い方

平山 英夫、波戸 芳仁

KEK, High Energy Accelerator
Research Organization

28 JUL 2004

Body の定義

- 以下のbodyを使う事ができる
 - Rectangular Parallelepiped (RPP)
 - Sphere (SPH)
 - Right Circular Cylinder (RCC)
 - Truncated Right Angle Cone (TRC)
 - Torus (TOR)

RPP

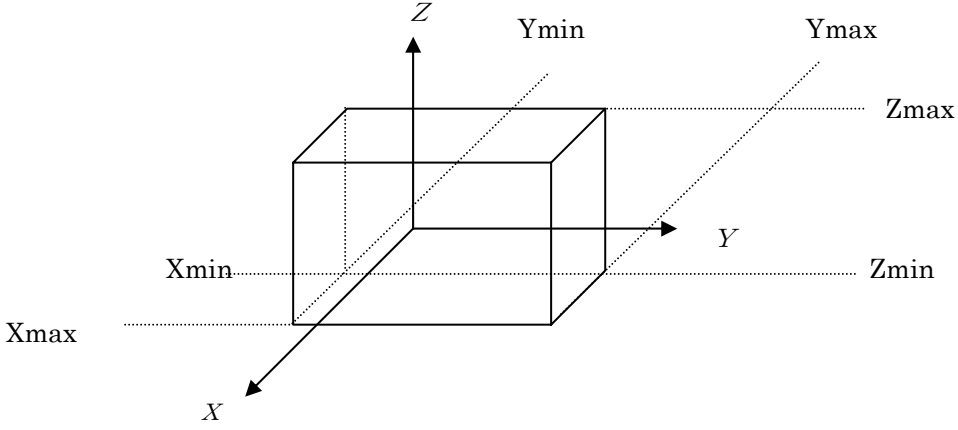

SPH

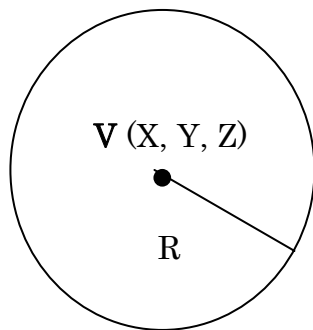

RCC

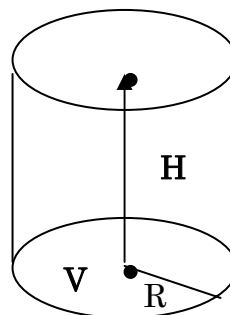

TRC

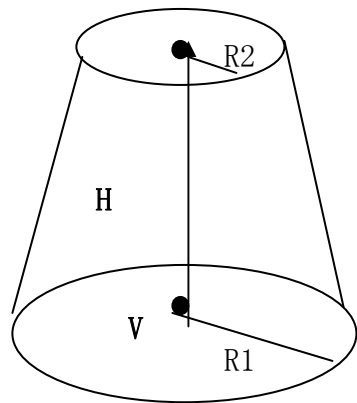

TOR

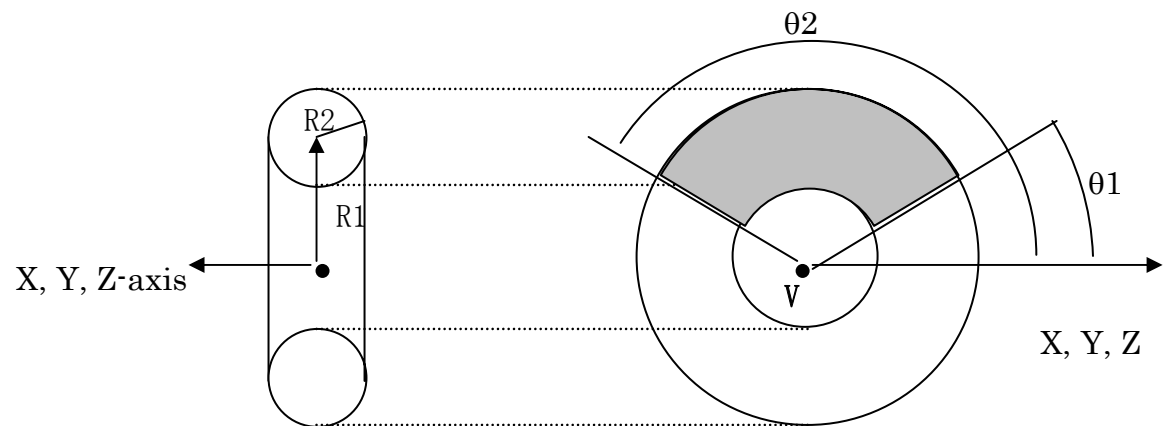

Direction of torus

N-1:X, n=2: Y, n=3:Z axis

Bodyの書き方

- RPP No. X_{\min} X_{\max} Y_{\min} Y_{\max} Z_{\min} Z_{\max}
- SPH No. V_x V_y V_z R
- RCC No. V_x V_y V_z H_x H_y H_z R
- TRC No. V_x V_y V_z H_x H_y H_z R_1 R_2
- TOR No. V_x V_y V_z R_1 R_2 θ_1 θ_2 n

リージョンの定義

- + : bodyの内側の領域
- - : bodyの外側の領域
- OR : 次の様に使用される。
 - +2 OR +3 : body 2か3に含まれる領域
 - OR +3 -1 OR +3 -2 : body 3の内側でbody 1の外側か、body 3の内側でbody 2の外側の領域

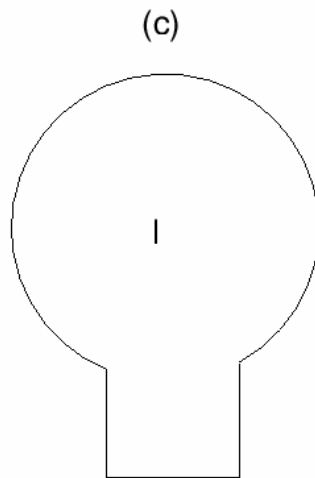
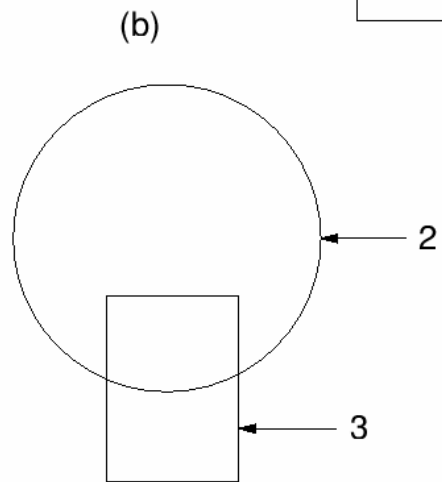
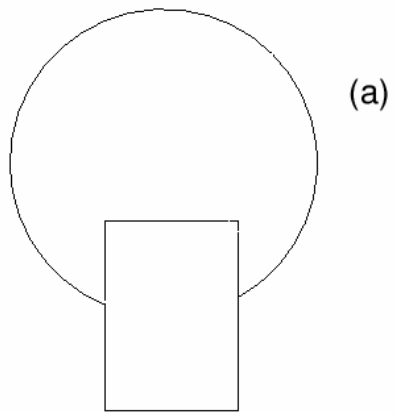

$I = +2 \text{ OR } +3$

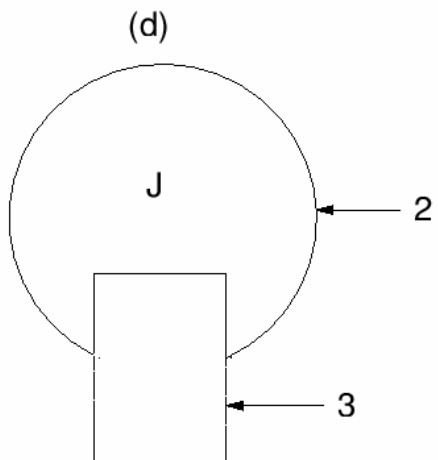

$J = +2 -3$

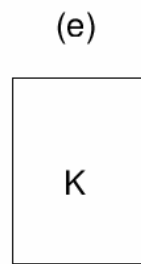

$K = +3$

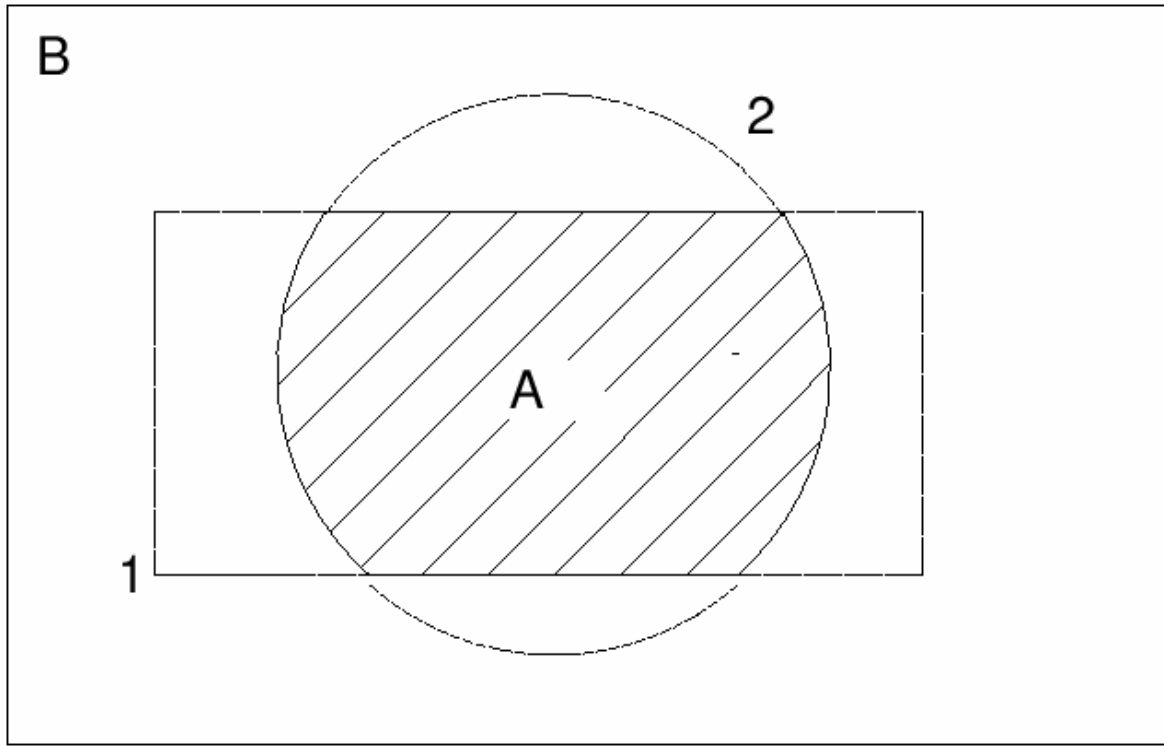

$$A = +1 \ +2$$

$$B = +3 \ -1 \ \text{OR} \ +3 \ -2$$

sample I

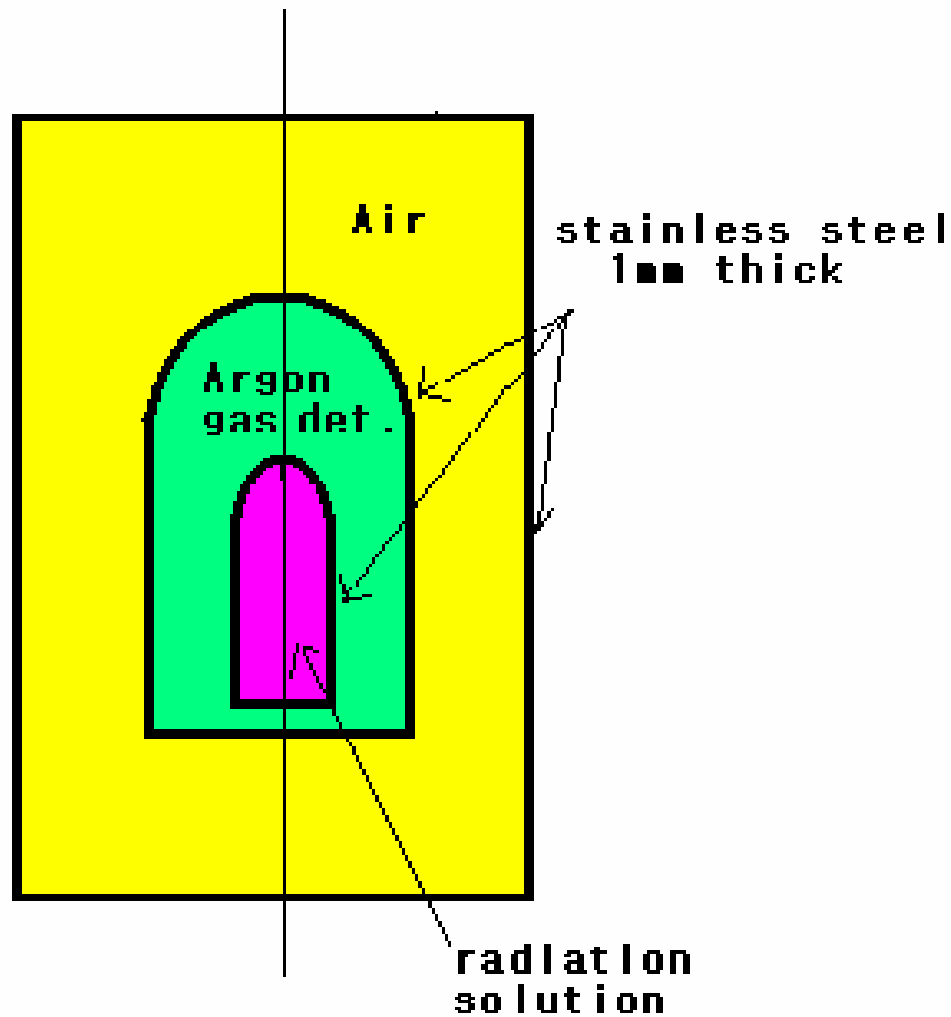

cylindrical detectors
having regions
partially spherical

RCC	1	0.0	0.0	0.0	0.0	0.0	30.0
							10.0
RCC	2	0.0	0.0	0.1	0.0	0.0	29.8
							9.9
RCC	3	0.0	0.0	5.0	0.0	0.0	15.0
							5.0
RCC	4	0.0	0.0	5.1	0.0	0.0	14.9
							4.9
RCC	5	0.0	0.0	6.0	0.0	0.0	8.0
							2.0
RCC	6	0.0	0.0	6.1	0.0	0.0	7.9
							1.9
SPH	7	0.0	0.0	14.0	1.9		
SPH	8	0.0	0.0	14.0	2.0		
SPH	9	0.0	0.0	20.0	4.9		
SPH	10	0.0	0.0	20.0	5.0		
RCC	11	0.0	0.0	-1.0	0.0	0.0	40.0
							15.0

END

Z1	+6 OR +7	←	Region 1 Solution
Z2	+5 -6 OR +8 -7 -5	←	Region 2 Fe cover
Z3	+4 -5 -8 OR +9 -4	←	Region 3 Ar detetor
Z4	+3 -4 OR +10 -9 -3	←	Region 4 Fe cover
Z5	+2 -3 -10	←	Region 5 Air
Z6	+1 -2	←	Region 6 Fe cover
Z7	+11 -1	←	Discard region
END			

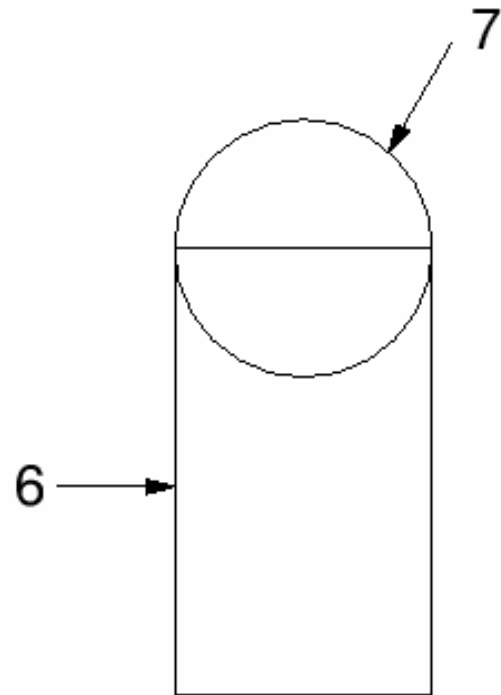

Z1: +6 OR +7

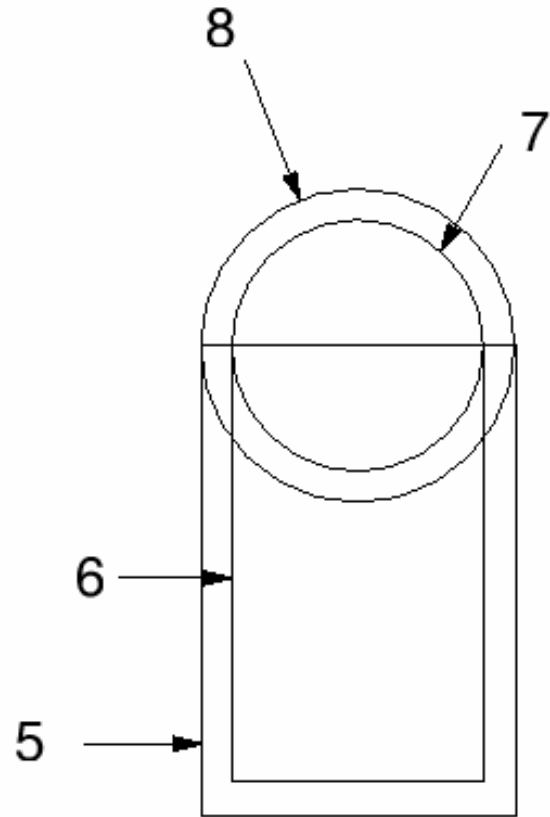

Z2: +5 -6 OR +8 -7 -5

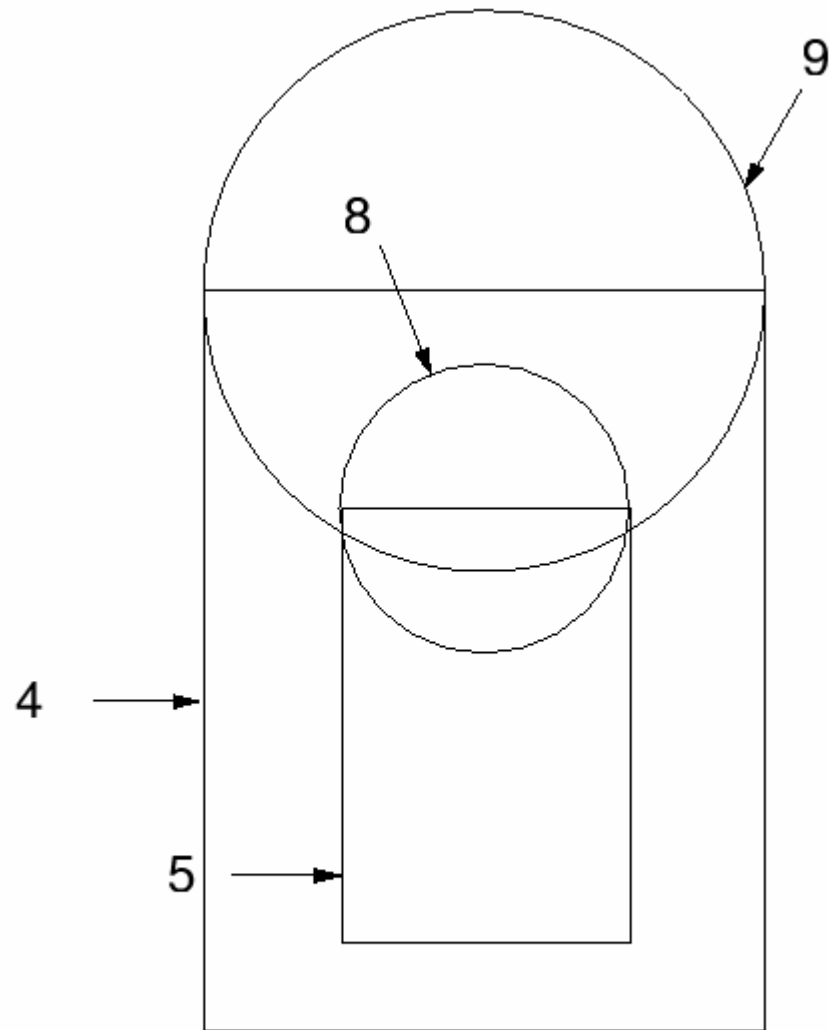

Z3: +4 -5 -8 OR +9 -4

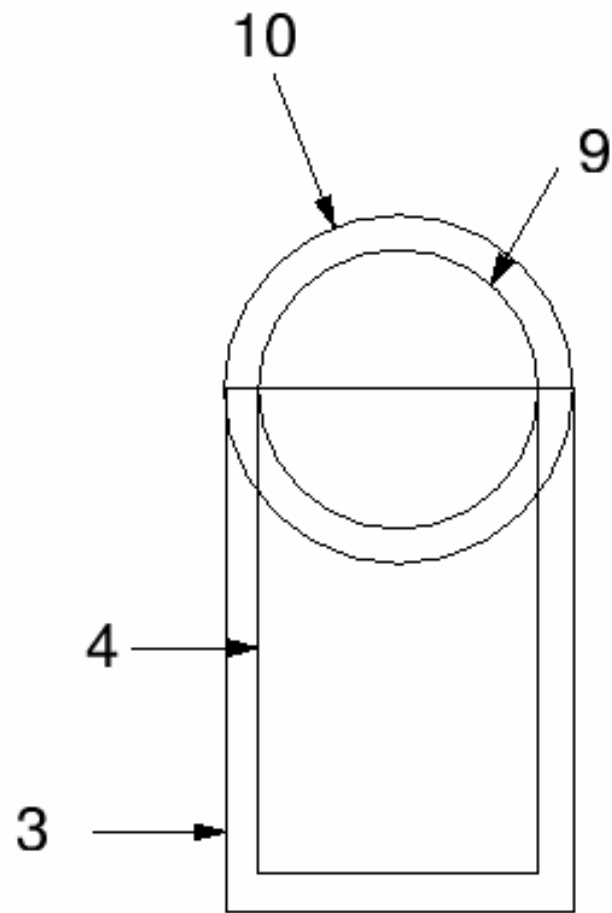

Z4: +3 -4 OR +10 -9 -3

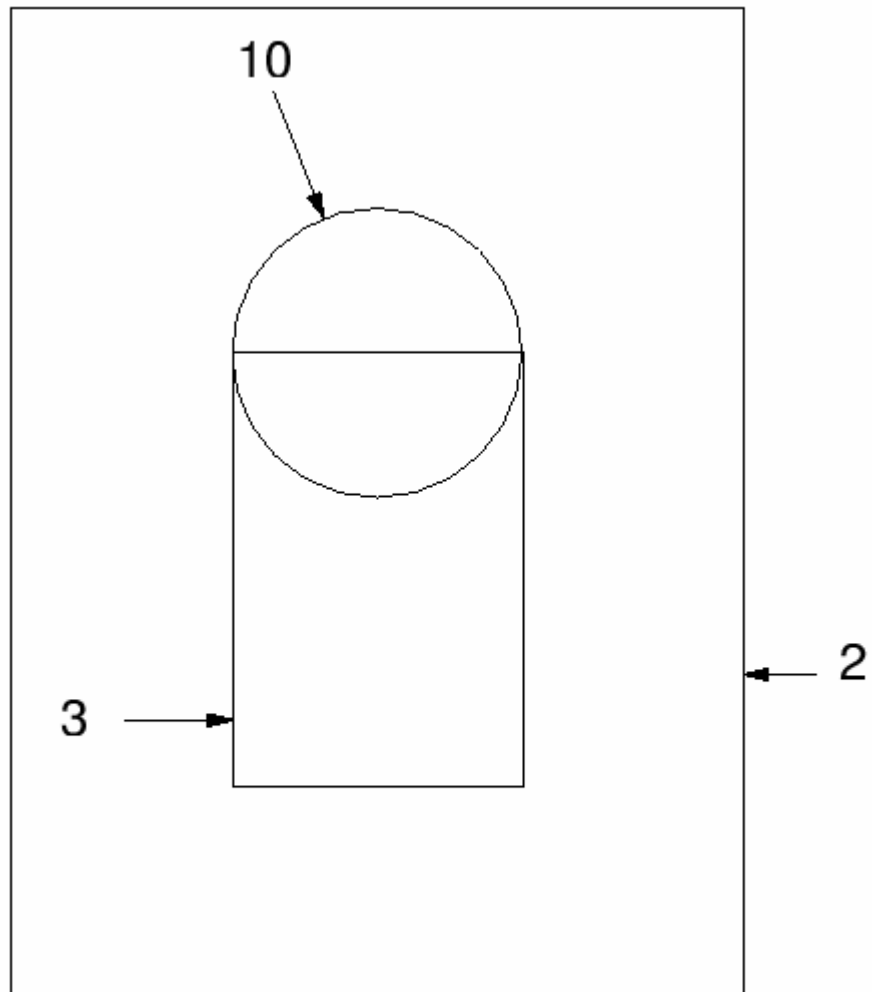

Z5: +2 -3 -10

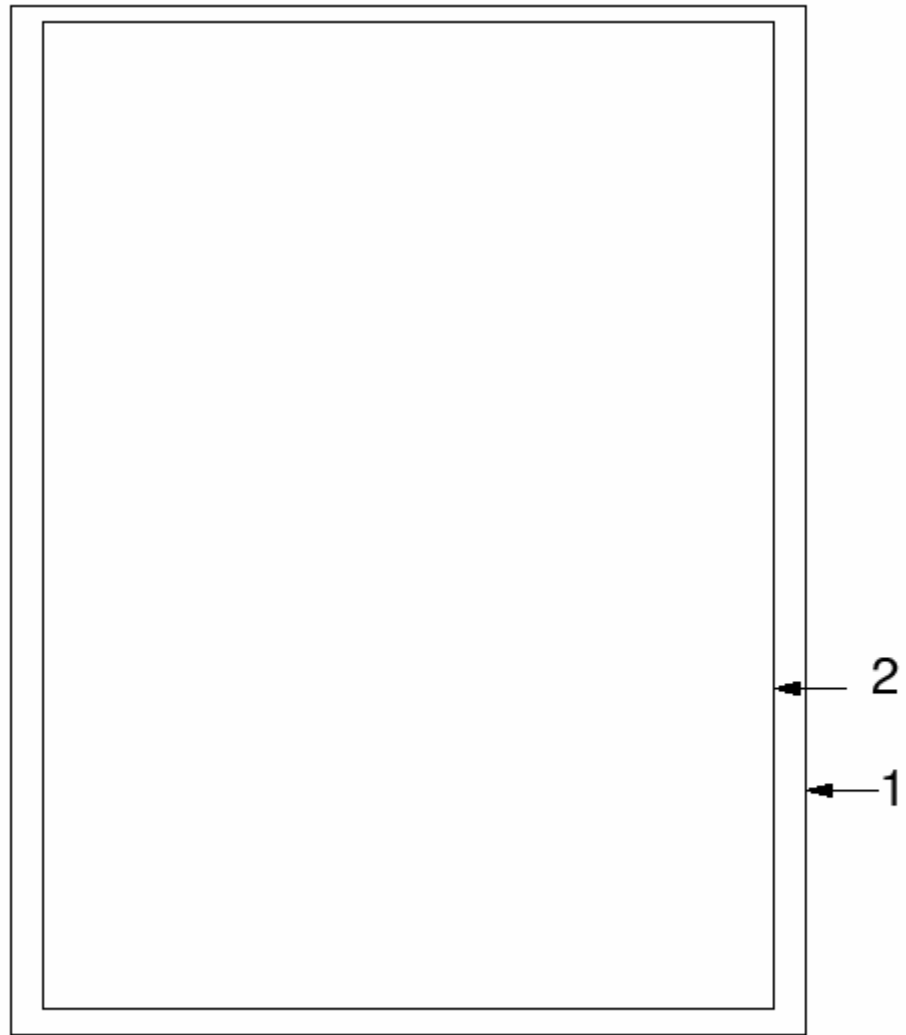

Z6: +1 -2

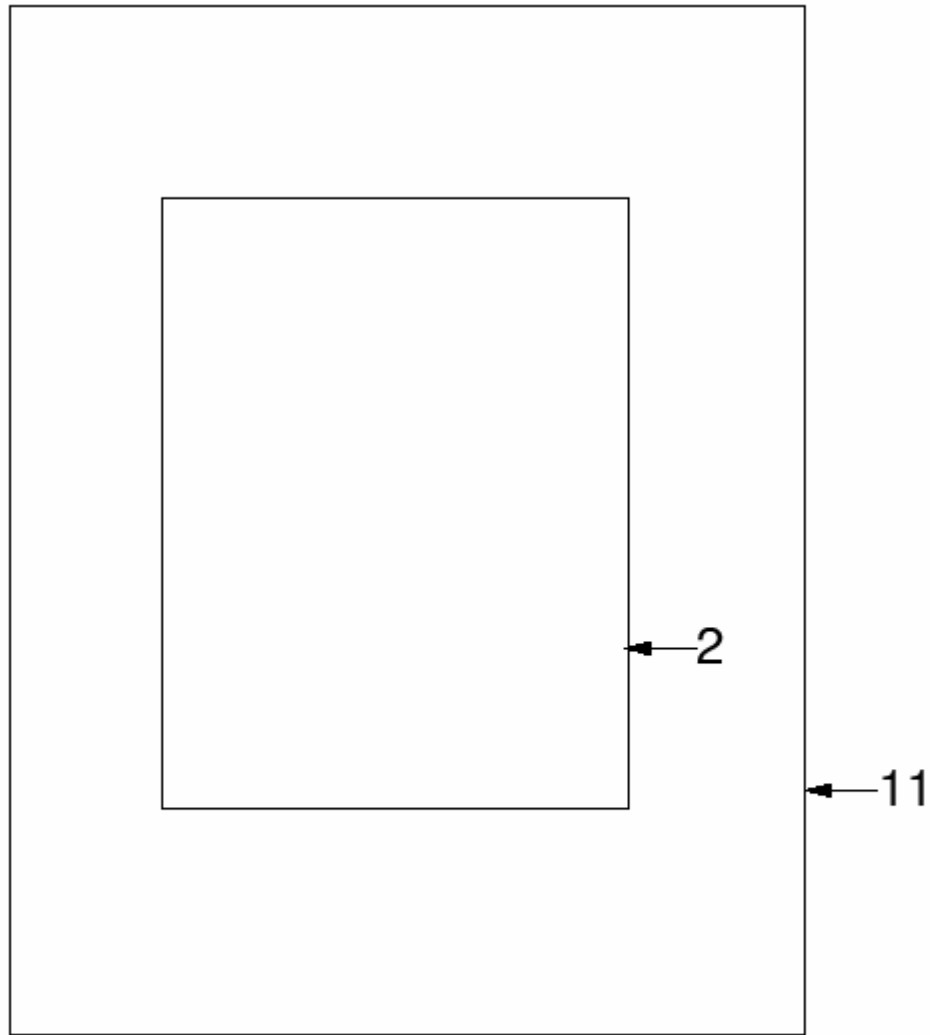

Z7: +11 -1